

# MODEL 300

(Spline011)

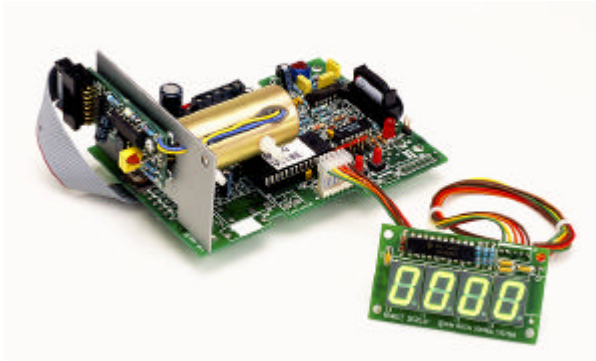

## CO<sub>2</sub> CONCENTRATION SENSOR

### REFERENCE MANUAL

#### DIGITAL CONTROL SYSTEMS

7401 SW Capitol Hwy.

Portland, OR 97219 USA

503/246-8110 ♦ 503/246-6747 (fax)

© 2002

**Date**

3/21/00

6/02/00

7/11/00

6/24/02

6/13/07

# Model 300 CO<sub>2</sub> Concentration Sensor

---

## TABLE of CONTENTS

<b>INTRODUCTION .....</b>	<b>1</b>
<b>SPECIFICATIONS .....</b>	<b>2</b>
<b>OPERATIONAL DESCRIPTION.....</b>	<b>2</b>
<b>Operating Power Requirements.....</b>	<b>3</b>
<b>Analog Measurement Output.....</b>	<b>3</b>
Voltage Output .....	3
Current Output.....	4
<b>Full Scale Turn-down .....</b>	<b>4</b>
<b>OPTIONS.....</b>	<b>5</b>
<b>Digital Display .....</b>	<b>5</b>
<b>High Limit Contact Closure.....</b>	<b>5</b>
<b>INSTALLATION.....</b>	<b>6</b>
<b>Detector Mounting.....</b>	<b>6</b>
Pumped Sample Draw Considerations.....	7
<b>Control Board Mounting.....</b>	<b>7</b>
Cable Connections .....	8
<b>Display Board Mounting .....</b>	<b>10</b>
<b>POWER UP SELF-TEST .....</b>	<b>10</b>
<b>ELEVATION SETTING .....</b>	<b>10</b>
<b>MEASUREMENT CALIBRATION.....</b>	<b>11</b>
<b>ANALOG OUTPUT SCALING CORRECTION.....</b>	<b>12</b>
<b>Analog Output Zero Adjustment Check.....</b>	<b>13</b>
<b>Analog Output Span Adjustment Check.....</b>	<b>13</b>
<b>LIMITED WARRANTY AND REMEDIES.....</b>	<b>15</b>

# **Model 300 CO<sub>2</sub> Concentration Sensor**

---

## **INTRODUCTION**

The Model 300 is a microprocessor based, non-dispersive infrared CO<sub>2</sub> concentration sensor. The amount of power impinging on the detector is an approximately logarithmic function of the CO<sub>2</sub> concentration in the gas between source and detector. The wavelengths used are absorbed only by CO<sub>2</sub>, making the measurement insensitive to other components, such as water vapor, in the gas being measured.

The Model 300, supplied in a "bare board" configuration, is a cost effective measurement component for a variety of scientific and industrial products. Advanced design provides a very stable, drift-free output requiring less frequent calibration.

Its microprocessor based design keeps analog signal processing, with its troublesome limitations to a minimum. Detector linearization is performed with 32 bit digital accuracy. Concentration can be transmitted to another device via a voltage or a 4 to 20 milliamp current loop interface, or directly displayed with the optional LED read-out.

The Model 300 is available in several versions. The detector assembly can be provided in a remote, bulkhead mounted configuration, intended primarily for measuring CO<sub>2</sub> concentration in enclosed spaces or directly mounted to the control board. Both types can be supplied with hose nipples for pumped sample draw systems, or with multiple sampling ports for diffusion applications.

## Model 300 CO<sub>2</sub> Concentration Sensor

---

### SPECIFICATIONS

<b>Sensing Technique</b>	Non-dispersive infrared (NDIR)
<b>Measurement Range</b>	0 - 20% CO <sub>2</sub> contact factory for other ranges
<b>Maximum Drift (per year)</b>	± 3% of full scale
<b>Accuracy</b>	±5% of reading or 0.1% CO <sub>2</sub> , whichever is greater
<b>Repeatability</b>	better than 0.1% CO <sub>2</sub>
<b>Measurement Outputs</b>	Linear
voltage	0 - 1 volt is standard, other ranges available
current loop	4 - 20 mA ( $R_{loop} \leq 470\Omega$ )
digital display	7 segment LED showing CO <sub>2</sub> concentration
<b>Operating Temperature Range</b>	0 - 50 <sup>0</sup> C
<b>Storage Temperature</b>	-20 to +70 <sup>0</sup> C
<b>Power Requirement</b>	10-35 VDC 8 - 28 VAC <sub>rms</sub> Approx. 1.5W  250 mA max with optional digital display
<b>Optional Digital Display</b>	3 digit LED

### OPERATIONAL DESCRIPTION

The Model 300 CO<sub>2</sub> sensor consists of a control board and a detector assembly connected with a flat ribbon cable. The sensor/control board pairs are factory calibrated as a unit and should not be separated.

# Model 300 CO<sub>2</sub> Concentration Sensor

---

## Operating Power Requirements

The Model 300 requires approximately 170 mA of peak current at a minimum of 8 volts DC. The current wave form has an AC component of about 50 mA peak to peak at a frequency of approximately two hertz.

Low voltage operating power is applied at the "V+" and "V-" screw terminals of J50. **Reversing the input power polarity when the 'COM' terminal is connected to ground will damage the output voltage driver.**

Maintaining adequate input voltage is critical. **Input voltages below 8 volts will result in erroneous readings.**

If the digital display option is connected, the current draw increases to a maximum of 250 mA.

## Analog Measurement Output

The measured CO<sub>2</sub> concentration is available as either a voltage or current signal whose amplitude is linearly proportional to the measured concentration. While both outputs are always present, they share a single set of calibration parameters; they can not be independently calibrated.

Calibration of the analog outputs is done as starting on page 13. Note that this calibration only adjusts the analog signal that is generated in response to the measured concentration level. The concentration measurement itself is calibrated as described in the *Measurement Calibration* section starting on page 11.

## **Voltage Output**

The Model 300 CO<sub>2</sub> sensor indicates the CO<sub>2</sub> concentration measured by the sensor as a DC voltage at the "V OUT" (positive) and "COM" terminals of J50. The standard output voltage range is from 0 to 1.0 volts as CO<sub>2</sub> concentration ranges from zero to full scale. Other voltage ranges are available.

The "COM" terminal is the reference potential for the output voltage. For best accuracy the ground of the circuit that receives the output signal should be referenced to the "COM" terminal rather than the negative side of the power supply connected to the "V -" terminal.

## **Model 300 CO<sub>2</sub> Concentration Sensor**

---

Because of varying voltage drops caused by the varying IR source current that flows out of the "V -" terminal, the voltage at the "COM" terminal may vary by tens of millivolts relative to the potential at the other end of the wire connected to the "V -" terminal.

### **Current Output**

The Model 300 supplies a current ranging linearly from 4 to 20 milliamps as the CO<sub>2</sub> concentration varies from 0 to full scale. The current flows out of the "I OUT" terminal at J50 and returns through the "COM" terminal. The maximum load resistance through which the full scale current can be driven increases at higher supply voltages. With a 12 volt input the maximum resistance is about 500 Ohms. Excessive resistance between the "I OUT" and "COM" terminals will result in low reading errors at higher concentrations.

### **Full Scale Turn-down**

The full scale concentration of the unit can be decreased from the factory calibration full scale value. For example a Model 300 factory calibrated as a 20% full scale unit can be adjusted so that any concentration below 20% becomes the new top of scale.

Changing the full scale calibration value has two effects. The digital display clips at the selected concentration value, and the analog output scaling is changed so that the selected maximum concentration value corresponds to the full scale analog output.

A Model 300 factory calibrated for 0 to 20% that is turned down to 10% full scale can never indicate more than 10% CO<sub>2</sub> on the display, and its analog outputs will be at full scale when the indicated concentration reaches 10%.

To turn down the full scale value of a Model 302 proceed as follows:

- 1) Note whether the shorting block at JP5 is covering one or both pins, then remove it and use it to close jumper JP4.
- 2) While JP4 is closed, use another shorting block to close jumper JP3.
- 3) If the optional display is connected it will show the full scale value.

## Model 300 CO<sub>2</sub> Concentration Sensor

---

The analog output value will be the same fraction of its full scale value as the turn down ratio. For example if a 20% unit is turned down to 10% full scale, the analog output will be at ½ of its maximum value (i.e. the voltage will be at .5 V and the current will be 12 mA).

- 4) Use the 'UP' and 'DOWN' buttons to set the desired full scale value.
- 5) Remove the shorting block from JP3 and store it by sliding over only a single pin of JP3. Remove the shorting block from JP4 and replace it at its original position over one or both pins of jumper JP5.

### Options

This section describes operational features that may not be present on all units.

#### Digital Display

The CO<sub>2</sub> concentration can be directly displayed on an optional three digit LED display. The display cable is connected to the 5 pin locking header marked "DISPLAY" at the lower left edge of the control board.

The displayed concentration is calibrated with the measurement calibration procedure (see page 11). Analog calibration has no effect on the displayed value.

#### High Limit Contact Closure

The optional contact closure provides a dry (i.e. unpowered) contact at the two terminals of J3. The set point is adjustable over the full range of the unit by closing jumper 3 and using the buttons to select the desired value. If the optional display is installed, the setpoint value is displayed while jumper 3 is closed. If the display is not present the voltage or current output will indicate the set point while jumper 3 is closed.

Jumper 5 sets the polarity of the contact.

Jumper 5 ON	Contact <b>closed above</b> set point
Jumper 5 OFF	Contact <b>open above</b> set point



# Model 300 CO<sub>2</sub> Concentration Sensor

Relay contacts are rated at 2A/24V.

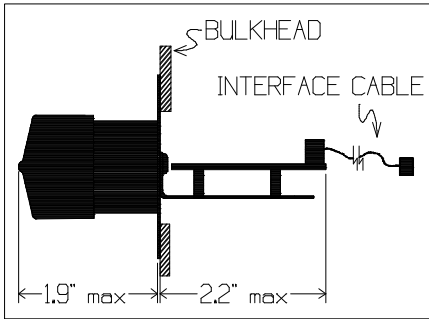

Figure 1: Typical Bulkhead Style Detector Mounting

## INSTALLATION

### Detector Mounting

The remote and attached detector versions differ only in the mechanical configuration of the electronics module. Detectors should be placed so that they are not subject to excessive vibration or shock which could alter their calibration or decrease their operating life.

The remote detector is intended primarily for monitoring the CO<sub>2</sub> concentration through a bulkhead in enclosed spaces. Figure 1 shows a typical installation. A hole pattern similar to Figure 2 is provided in the wall, and the sensor assembly is installed from

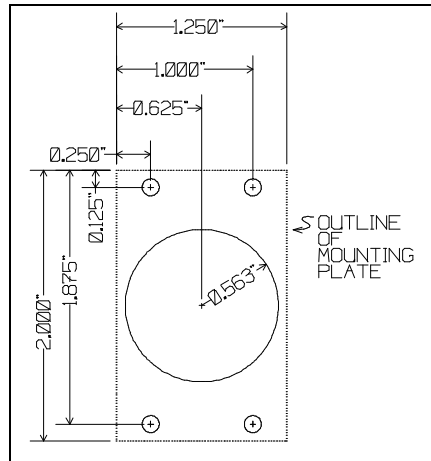

Figure 2: Bulkhead Detector Mounting Pattern

## **Model 300 CO<sub>2</sub> Concentration Sensor**

---

inside the area to be monitored, with its mounting plate fastened to the inside of the wall.

The board mounted detector is intended for pumped sample draw applications where the detector location is not critical. The detector is mounted to the control board with a bracket. The control board requires an additional 1/2" of clearance at the edge of the board opposite the detector connector to accommodate the detector electronics (see control board layout diagram on page 8.).

### **Pumped Sample Draw Considerations**

To avoid excessive pressure build-up in the detector, place filters or other flow restricting devices upstream of the sample cell.

Place the detector in the high pressure side of the system, so that any leaks discharge sample gas rather than drawing in ambient air and altering the concentration of the sample stream.

When sampling high humidity gas, the detector chamber must be kept above the dew point of the sample stream to avoid condensation. **Any liquid water inside the sensing cell will cause concentration reading errors.**

In high flow systems a shunt tube should be provided, to avoid inducing turbulence in the sample chamber that may cause unstable readings when the flow rate exceeds 0.25 l/min.

### **Control Board Mounting**

The control board has four .125" diameter mounting holes, and can be mounted in any orientation. Overall board size and mounting hole locations are shown below. The board must be mounted a minimum .5" above any conducting surface, and should be positioned so that there is easy access to its lower right hand corner where the jumpers and buttons used for calibration are located. The required clearance above the board is 2.5". If the detector is mounted to the control board, an additional 1/2" of clearance is required on the side of the board opposite the detector connector.

# Model 300 CO<sub>2</sub> Concentration Sensor

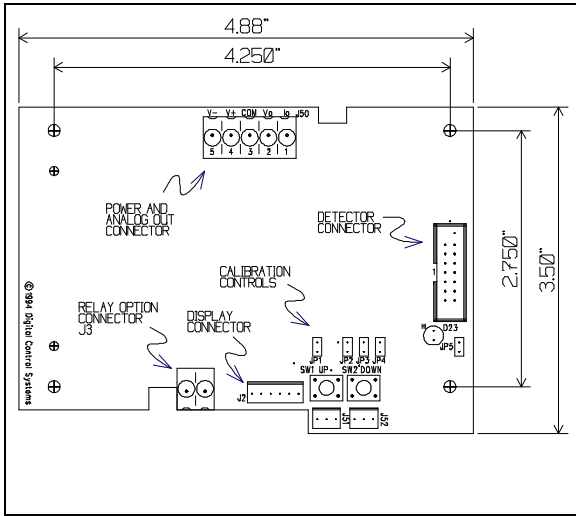

**Figure 3:** Control Board Layout

## Cable Connections

All power and signal connections to the Model 300 are summarized in Table 1 below.

For best noise immunity, the signal output wires should be twisted together and not routed for long distances close to power carrying conductors.

## Model 300 CO<sub>2</sub> Concentration Sensor

---

Terminal Number	Contact Name	Signal Description	Comments
J1	none	The detector assembly ribbon cable is connected here.	Detector assembly should not be connected while the control board is under power.
J2	DISPLAY	The optional digital LED display is connected here.	.
J50	V-	Negative side of supply voltage.	#16 AWG or larger wire should be used to supply the operating power.
	V+	Positive side of supply voltage Must be at least 8 volts DC relative to 'V-' terminal.	
	I OUT	Source terminal for current loop analog output.	The current loop is connected between this terminal and "COM".
	V OUT	Voltage proportional to CO <sub>2</sub> concentration is present at this terminal.	
	COM	Reference potential for output signal voltage, and return for current signal.	When the voltage output is used, the receiving circuit should use this pin rather than "V-" as the reference potential.

**TABLE 1: Control Board Connector Summary**

# Model 300 CO<sub>2</sub> Concentration Sensor

## Display Board Mounting

The display board dimensions are shown in the figure below. The most straightforward installation technique is to mount the display board behind a panel using 3/8" standoffs, with a 1.6" by .75" cutout centered on the middle LED digit. A translucent window the same color as the LEDs will greatly enhance the viewing contrast.

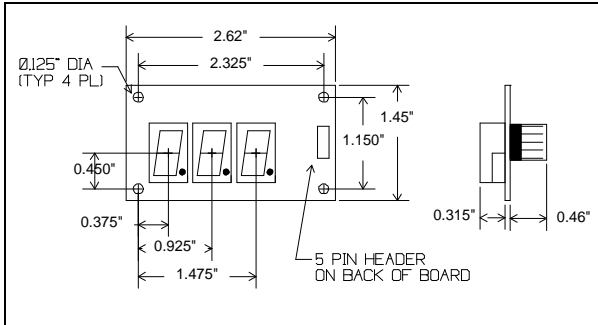

**Figure 4:** Remote Display

## POWER UP SELF-TEST

Whenever power is applied the software version number is displayed on the LED read out, and the calibration data stored in the EEPROM in the detector assembly is read and verified. If an error is detected the analog outputs will continue to indicate maximum concentration and the digital display will continue to show the software revision number.

## ELEVATION SETTING

To set the operating elevation of the sensor proceed as follows:

1. Apply operating power to the unit and remove the front cover if necessary to gain access to the calibration jumpers and buttons.
2. If the unit does not have an integral display, connect a remote display to the display connector on the unit. See Figure 3 for location of display connector.
3. Press and hold both the 'UP' and 'DOWN' buttons, then close jumper JP2 with a shorting block and release both buttons.

## **Model 300 CO<sub>2</sub> Concentration Sensor**

---

The display will show the current operating elevation in feet. On units with 3 digit displays, only the most significant three digits of the elevation will be shown (i.e. an elevation setting of 300 feet would be displayed as '030'). On four digit displays the rightmost digit will show a value between 0 and 9. Ignore this digit; its value is meaningless.

4. Use the 'UP' and 'DOWN' buttons to change the elevation display (in 10 feet increments) until it shows the current elevation to the nearest 10 feet. For example if the sensor is to operate at an elevation of 3573 feet, set the display to read '357' on a three digit display or '357x' (where x is any value) on a four digit display.
5. When the correct value is showing in the display, remove the shorting block at jumper JP2. The display will revert to showing the current CO<sub>2</sub> concentration corrected for the specified elevation.
6. The gas calibration can now be verified or adjusted using the normal gas calibration procedures.

### **MEASUREMENT CALIBRATION**

The non-linear gas measurement calibration parameters for each detector assembly are established during factory calibration and stored in the EEPROM on the detector electronics module.

Sensors are calibrated during manufacture at 20oC and atmospheric pressure of approximately 1000 millibars. When placed in service at significantly different temperatures and/or pressures, the measurement should be calibrated at the actual operating conditions. This is especially important in pumped sample systems, where the ambient pressure seen by the detector may vary significantly from the factory calibration conditions.

Measurement calibration is used to make the Model 300 accurately report the CO<sub>2</sub> concentration at the prevailing temperature and pressure. If the voltage or current output is used to indicate the measured CO<sub>2</sub> percentage, the analog output span and offset must be correct before the measurement calibration can be accurately established.

## **Model 300 CO<sub>2</sub> Concentration Sensor**

---

To perform a measurement calibration proceed as follows:

**Measurement calibration CAN NOT be done at CO<sub>2</sub> concentrations of less than 10% of full scale.**

1. Ensure that the detector has stabilized at its normal operating temperature.
2. Establish an accurately known CO<sub>2</sub> concentration between 10% and 100% of full scale at the detector.
3. Note whether the shorting block on jumper JP5 covers both pins or only a single pin. Remove the shorting block and use it to connect the two pins marked 'JP2' on the control board.
4. Use the 'UP' and 'DOWN' buttons to alter the measured CO<sub>2</sub> concentration as indicated by the digital readout or the analog output until it corresponds to the known CO<sub>2</sub> concentration

because of internal averaging, there will be a several second lag before changes caused by pressing the 'UP' or 'DOWN' buttons are reflected in the display or analog output value.

for changes of more than a few tenths of a percent, hold the appropriate button down until the output is close to the desired value, then make the final adjustment after the output settles.

5. Remove the shorting block from JP2 and replace it in its original position in jumper JP5. The new calibration value is saved in the internal EEPROM.

When jumper JP2 is opened, the output will be erratic for several seconds before returning to the calibrated value.

### **ANALOG OUTPUT SCALING CORRECTION**

The analog voltage or current output generated by the Model 300 in response to the detected CO<sub>2</sub> concentration can be adjusted to match the input characteristics of the indicating device. Both the gain and offset of the analog output can be adjusted with the following procedures.

## Model 300 CO<sub>2</sub> Concentration Sensor

---

### Analog Output Zero Adjustment Check

**This adjustment does not calibrate the accuracy of the CO<sub>2</sub> concentration measurement.**

This procedure is used to check that the Model 300's analog output (either current or voltage) makes the indicating circuit to which it is connected register correctly at the low end of the scale. This check can be made regardless of the CO<sub>2</sub> concentration at the detector.

To adjust the analog output zero calibration proceed as follows.

- 1) Connect a volt or current meter to the output terminals.
- 2) Use a shorting block to connect the two pins of jumper JP4. If installed, the display will read 005.
- 3) Use the 'UP' and 'DOWN' buttons to adjust the output as shown in the table below.

Output	Zero Cal. Value
4 - 20 mA	4.080mA
0 - 1 Volts	0.005 Volts

- 4) Remove the shorting block from jumper JP4.

### Analog Output Span Adjustment Check

**This adjustment does not calibrate the accuracy of the CO<sub>2</sub> concentration measurement.**

The analog output span adjusts the amount of change in the analog output signal for a given change in measured CO<sub>2</sub> concentration. It is used only to adjust the gain of the analog output signal to match the input characteristic of the indicating circuit it drives. The span check can be done regardless of the actual concentration at the detector.



## Model 300 CO<sub>2</sub> Concentration Sensor

---

To adjust the analog output span proceed as follows.

- 1) Be sure that jumpers JP4 and JP5 are open
- 2) Close jumper JP5 with a screwdriver. While JP5 is closed use a shorting block to connect the two pins of jumper JP4. Jumper JP5 can be opened after JP4 is closed. If installed, the display will read 950.
- 3) Use the 'UP' and 'DOWN' buttons to adjust the output as shown in the table below.

Output	Span Cal. Value
4 - 20 mA	19.20 mA
Voltage	0.950 Volts

- 4) Remove the shorting block from jumper JP5